

# TOSHIBA

The intelligent automotive  
display controller

## Capricorn Family



## Applications

More and more cars are equipped with infotainment systems using a TFT display. Typical applications areas are  
 Car navigation systems  
 Driver information systems  
 Telematic systems  
 Rear seat entertainment systems

Such systems require a processor and a graphic display controller (GDC). Toshiba put both devices on one chip, minimizing the component count, utilising a unified memory architecture and therefore enabling a cost-effective and powerful implementation of infotainment applications.



## One-chip System Concept

- Processor & display controller on a single chip
- Minimum component count
- Large bandwidth available for CPU and GDC due to separated internal buses
- Unified memory architecture  
 Direct CPU access to the frame buffer for fast direct graphics manipulations
- Integrated CAN controllers  
 • Bridge  
 • GPS  
 • ABC  
 • ATAPI
- Lower EMI  
 Fewer external bus connections
- Better reliability  
 Less components and fewer connections
- Reduced qualification effort required

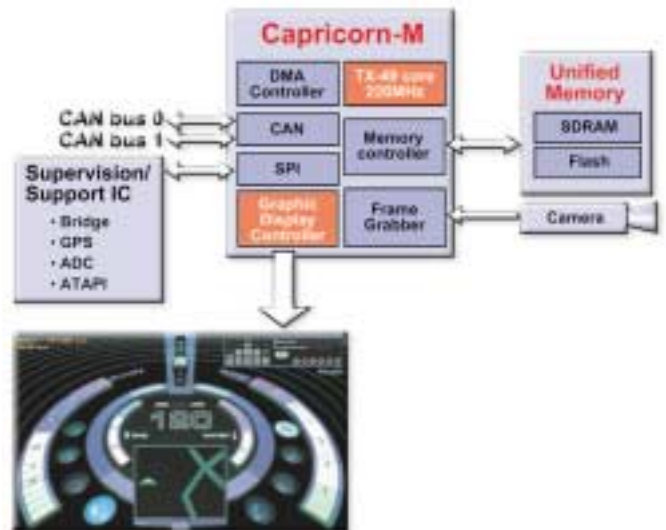

## Capricorn Roadmap

Toshiba developed a series of Capricorn devices responding to the needs of different applications and is continuously enlarging this family to fulfil the demands of future infotainment systems with ever enhanced functionalities.

The Capricorn ASSPs are developed by Toshiba's European LSI Design and Engineering Centre (ELDEC). Evaluation boards are available for Capricorn-2 and Capricorn-M.

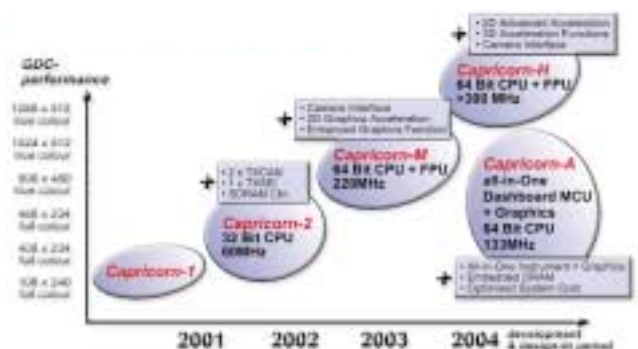



## Capricorn M Key Features

- 64-Bit TX49 Core, 220MHz, FPU
- Quad G-Bus DDR-SDRAM-Controller
- Graphics Display Controller
  - Display resolution up to 800 x 600 dots
  - 5 Layers ( 4 Main + Hardware-Cursor)
  - Smooth scrolling function for all layers
  - Video artefact handling
- Frame Grabber
  - Supports several input formats (RGB & YCbCr)
  - Capable of resolutions of up to 1024x512 dots
  - Picture-Cropping
  - Bilinear filtered pixel-by-pixel up and downscaling
- Graphics Accelerator
  - Drawing-Engine (high quality antialiasing)
  - Blitter-Engine
- Memory Controller
  - DDR-SDRAM: 2 channel
  - Flash, EBIF, async. SRAM: 4 channel
- Peripheral Blocks
  - Interrupt Controller
  - 4 x DMA Controller
  - 2 x CAN, 2 x SPI, 2 x UART
  - Timers, PWM Timer, General Purpose I/Os
- Capricorn M is currently developed in Europe

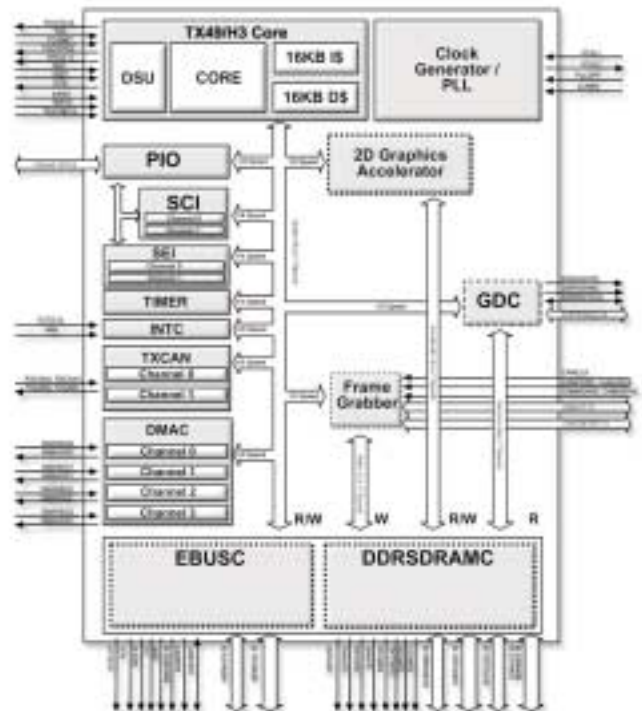

## Toshiba Offices in Europe

**GERMANY**  
**TOSHIBA ELECTRONICS EUROPE GMBH**  
**CENTRAL EUROPEAN SALES**  
 Düsseldorf  
 Hansaallee 181  
 40549 Düsseldorf  
 Tel.: +49-211-5 29 60  
 Fax.: +49-211-5 29 64 00

Munich  
 Hofmannstr. 52  
 81378 Munich  
 Tel.: +49-89-7 48 59 50  
 Fax.: +49-89-74 85 95 42

**ITALY**  
**TOSHIBA ELECTRONICS ITALIANA S.R.L.**  
 Milan  
 Centro Direzionale Colleoni  
 Palazzo Perseo Ingresso 3  
 20041 Agrate Brianza  
 Tel.: +39-39-6 87 01  
 Fax.: +39-39-6 87 02 05

**UK**  
**TOSHIBA ELECTRONICS (UK) LTD**  
 Camberley  
 Riverside Way  
 Camberley  
 Surrey  
 GU15 3YA  
 Tel.: +44-1276-69 46 00  
 Fax.: +44-1276-69 48 00

**FRANCE**  
**TOSHIBA ELECTRONICS FRANCE S.A.R.L.**  
 Paris  
 Les Jardins du Golf  
 6 rue de Rome  
 93561 Rosny-Sous-Bois, Cédex  
 Tel.: +33-1-48 12 48 12  
 Fax.: +33-1-48 94 51 15

**SPAIN**  
**TOSHIBA ELECTRONICS ESPAÑA S.A.**  
 Madrid  
 Parque Empresarial  
 San Fernando  
 28831 Madrid  
 Tel.: +34-1-6 60 67 98  
 Fax.: +34-1-6 60 67 99

**SWEDEN**  
**TOSHIBA ELECTRONICS SCANDINAVIA AB**  
 Bromma  
 Gustavslundsvägen 18  
 S-161 15 Bromma  
 Tel.: +46-8-7 04 09 00  
 Fax.: +46-8-80 84 59

Copyright and published by Toshiba Electronics Europe GmbH, August 2003.

Products or company names mentioned herein are Trademarks of their respective owners.

The information contained herein is subject to change without notice.

<http://www.semicon.toshiba.co.jp/eng/index.html>

TOSHIBA is continually working to improve the quality and reliability of its products. Nevertheless, semiconductor devices in general can malfunction or fail due to their inherent electrical sensitivity and vulnerability to physical stress. It is the responsibility of the buyer, when utilising TOSHIBA products, to comply with the standards of safety in making a safe design for the entire system, and to avoid situations in which a malfunction or failure of such TOSHIBA products could cause loss of human life, bodily injury or damage to property. In developing your designs, please ensure that TOSHIBA products are used within specified operating ranges as set forth in the most recent TOSHIBA products specifications. Also, please keep in mind the precautions and conditions set forth in the "Handling Guide for Semiconductor Devices," or "TOSHIBA Semiconductor Reliability Handbook" etc..

The Toshiba products listed on this document are intended for usage in general electronics applications (computer, personal equipment, office equipment, measuring equipment, industrial robotics, domestic

appliances, etc.). These Toshiba products are neither intended nor warranted for usage in equipment that requires extraordinarily high quality and/or reliability or a malfunction or failure of which may cause loss of human life or bodily injury ("Unintended Usage"). Unintended Usage include atomic energy control instruments, airplane or spaceship instruments, transportation instruments, traffic signal instruments, combustion control instruments, medical instruments, all types of safety devices, etc.. Unintended Usage of Toshiba products listed in this document shall be made at the customer's own risk.

The products described in this document may include products subject to the foreign exchange and foreign trade laws.

The information contained in this document is presented only as a guide for the applications of our products. No responsibility is assumed by TOSHIBA for any infringements of patents or other rights of the third parties which may result from its use. No license is granted by implication or otherwise under any patent or patent rights of TOSHIBA or others.